



QUICK INSTALLATION GUIDE

ES-BAT-4.8S

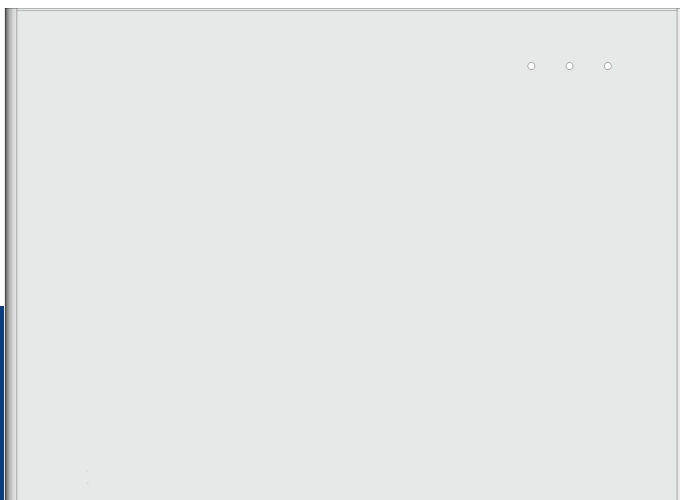

TABLE OF CONTENTS

01	INFORMATION ON THIS DOCUMENT	01
	1.1 Validity	01
	1.2 Target Group	01
	1.3 Content and Structure of this Document	01
02	SAFETY	02
	2.1 Intended Use	02
	2.2 Important Safety Instructions	02
	2.2.1 Battery Leakage Response	02
	2.2.2 Firefighting Measures	03
	2.2.3 Battery Handling and Storage Guide	03
	2.2.4 Warning of Electric Shock	03
	2.2.5 Notice of Property Damage	04
	2.2.6 Surge Protection	04
	2.2.7 Safety Information of the Inverter Manufacturer	04
03	SYMBOLS ON THE PRODUCT	05
04	EU DECLARATION OF CONFORMITY	07
05	UK DECLARATION OF CONFORMITY	07
06	INSTRUCTIONS	08
	6.1 Product Overview	08
	6.1.1 Interface	08
	6.1.2 LED Display	08
	6.2 Dimensions	12
	6.3 Spaces	12
	6.4 Scope of Delivery	13
	6.5 Mounting Location Requirements	14
	6.6 Installation	14
	6.6.1 Wall bracket installation	14
	6.6.2 Base Installation (Optional)	18
	6.7 Electrical Connection	21
	6.7.1 Electrical connection of the grounding	21
	6.7.2 Electrical Connection between Inverter and Batteries	21
	6.7.2.1 Electrical Connection between BW-INV-SPH or BW-INV-SPB	22
	series inverters and BW-BAT-4.8S	22
	6.7.2.2 Electrical Connection between BW-INV-TPH series inverters and BW-BAT-4.8S	23
	6.8 Install the Cable Cover (Option)	25
07	TECHNICAL DATA	26

1.1. VALIDITY

This document is valid for the ES-BAT-4.8S

1.2. TARGET GROUP

The instructions in this document may only be performed by qualified persons who must have the following skills:

- Knowledge of how batteries work and are operated
- Knowledge of how an inverter works and is operated
- Knowledge of, and adherence to the locally applicable connection requirements, standards and directives
- Knowledge of, and adherence to this document and the associated system documentation, including all safety instructions
- Training in dealing with the hazards associated with the installation and operation of electrical equipment and batteries
- Training in the installation and commissioning of electrical equipment

Failure to do so will make any manufacturer's warranty, guarantee or liability null and void unless you can prove that the damage was not due to non-compliance.

1.3. CONTENT AND STRUCTURE OF THIS DOCUMENT

This document contains safety information and instructions on installing, connecting and commissioning. Please finish reading this document before performing any actions on the product.

The latest version of this document and the comprehensive system manual for mounting, installation, commissioning, configuration and operation can be found in the Document Center on Cloud/APP.

Illustrations in this document are reduced to the essential information and may deviate from the real product.

2.1. INTENDED USE

This product is for residential and small business use and works with a PV plant.

It is a high-voltage Li-ion battery. It could be operated in either off-grid or on-grid mode with compatible inverters.

This product could be connected to the Internet through the inverter for maintenance and software updates.

This product must only be used as stationary equipment.

This product is suitable for outdoor and indoor use.

This product can only work with compatible inverters and you can find the compatible inverter list on Manufacturer's official website.

This product is not suitable for supplying life-sustaining medical devices. Please ensure that no personal injury would be inflicted due to the power outage of the system.

Alterations to the manufacturer's product, e.g. changes or modifications are not allowed unless a written permission from Manufacturer is obtained.

Any use of the product other than that described in the Intended Use section does not qualify as the intended use.

The attached document is an integral part of this product. Keep the documentation in a convenient, dry place for future reference and observe all instructions contained therein.

The type label should be always attached to the product.

2.2. IMPORTANT SAFETY INSTRUCTIONS

This product has been designed and tested under international safety requirements. However, to prevent personal injury and property damage and ensure the long-term operation of this product, please read this section carefully and observe all safety information at all times.

2.2.1. BATTERY LEAKAGE RESPONSE

If the batteries leak electrolyte, direct contact with the leaking liquid or gas should be avoided. The electrolyte is corrosive and the contact may cause skin irritation and chemical burns. If one is exposed to the leaked substance, please follow these instructions:

Inhalation: Evacuate the contaminated area, and seek medical help immediately.

Eye contact: Rinse eyes with flowing water for 15 minutes, and seek medical help immediately.

Skin contact: Wash the affected area thoroughly with soap and water, and seek medical help immediately.

Ingestion: Induce vomiting, and seek medical help immediately.

2.2.2. FIREFIGHTING MEASURES

The batteries may catch fire when it is put into fire. In case of a fire, please make sure that an ABC or carbon dioxide extinguisher is nearby. Do not use water to extinguish the batteries on fire.

Full protective clothing and self-contained breathing apparatus are required for the firefighters to extinguish the fire.

2.2.3. BATTERY HANDLING AND STORAGE GUIDE

- The batteries and their components should be protected from damage when transporting and handling.
- Weight of the battery may cause injury risk, please take the weight of this product into account during transportation and lifting.
- Do not impact, pull, drag or step on the batteries.
- Do not insert unrelated objects into any part of the batteries.
- Do not throw the batteries into a fire.
- Do not soak the batteries in water or seawater.
- Do not expose to strong oxidizers.
- Do not short-circuit the batteries.
- The batteries cannot be stored at high temperatures (more than 60°C).
- The batteries cannot be stored directly under the sun.
- The batteries cannot be stored in a high-humidity environment.
- Do not use the batteries if they are defective, appear cracked, broken or otherwise damaged, or fail to operate.
- Do not attempt to open, disassemble, repair, tamper with, or modify the batteries. The batteries are not user serviceable.
- Do not use cleaning solvents to clean the batteries.

2.2.4. WARNING OF ELECTRIC SHOCK

It is a danger to life due to electric shock when live components or DC cables are touched. The DC cables connected to this product may be live. Touching live DC cables results in death or serious injury due to electric shock.

- Do not touch non-insulated parts or cables.

- Disconnect the battery from the voltage source and make sure it cannot be reconnected before working on the device.
- Do not disconnect the battery power connectors under load, an electric arc may occur leading to electric shock and burns.
- Wear suitable personal protective equipment for all work on the battery.

2.2.5. NOTICE OF PROPERTY DAMAGE

If the product doesn't start at all, please contact Manufacturer service as soon as possible. Otherwise, the battery could be permanently damaged.

2.2.6. SURGE PROTECTION

Over-voltages (e. g. in the event of a flash of lightning) can be further conducted into the building and to other connected devices in the same network via the network cables or other data cables if there is no surge protection.

Ensure that this product is integrated into the existing surge protection.

2.2.7. SAFETY INFORMATION OF THE INVERTER MANUFACTURER

Please read and observe all safety information of the inverter manufacturer.

SYMBOL

EXPLANATION



Beware of a danger zone.
This symbol indicates that the product must be additionally grounded if additional grounding or equipotential bonding is required at the installation site.



Beware of electrical voltage.
The product operates at high voltages.



Risk of chemical burns.



Risk of explosion.



Risk of electrolyte leakage.



Fire, naked light and smoking are prohibited.
Keep the battery away from open flame or ignition sources.



Install the product out of reach of children.



Do not short circuit.



WEEE designation.
Do not dispose of the battery together with the household waste but in accordance with the disposal regulations for electronic waste applicable at the installation site.



Observe the documentation.
Observe all documents supplied with the system.



Refer to the instruction for operation.



Use eye protection.



CE marking.
The product complies with the requirements of the applicable EU directives.



RCM (Regulatory Compliance Mark), a brief guide to electrical equipment approvals in Australia.



The relevant device equipment conforms to the requirements specified in UK Directives.

WITHIN THE SCOPE OF THE EU DIRECTIVES

- Electromagnetic compatibility Directive 2014/30/EU (EMC).
- Electrical Apparatus Low Voltage Directive 2014/35/EU (LVD).
- Restrictions of Hazardous Substances Directive 2011/65/EU and (EU) 2015/863 (RoHS).
- Waste Electrical and Electronic Equipment 2012/19/EU.
- Registration, Evaluation, Authorization and Restriction of Chemicals (EC) No 1907/2006 (REACH).

Manufacturer confirms herewith that the products described in this document are in compliance with the fundamental requirements and other relevant provisions of the above-mentioned directives. The entire EU Declaration of Conformity can be found on manufacturer's official website.

**ACCORDING TO THE REGULATIONS OF ENGLAND,
WALES AND SCOTLAND**

- Radio Equipment Regulations 2017.
- The Restriction of the Use of Certain Hazardous Substances in Electrical and Electronic Equipment Regulations 2012.

Manufacturer confirms herewith that the products described in this document are in compliance with the fundamental requirements and other relevant provisions of the above-mentioned regulations. The entire UK Declaration of Conformity can be found on manufacturer's official website.

6.1. PRODUCT OVERVIEW

6.1.1. INTERFACE

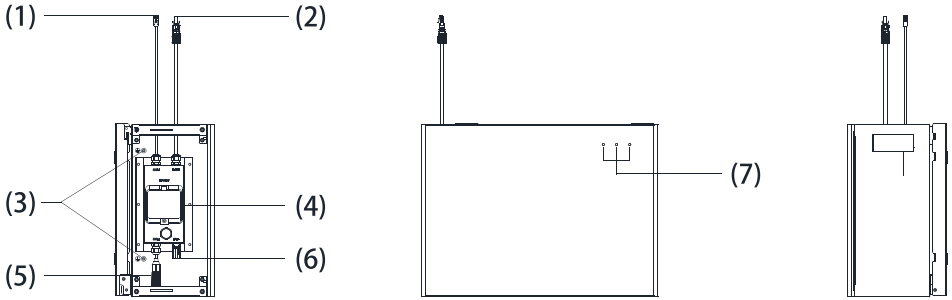

(1) BMS COM1

(2) BAT+ Power Connector

(3) Grounding Point

(4) Battery Circuit Breaker

(5) BMS COM2 (with terminal resistor)

(6) BAT- Power Connector

(7) LED Display

6.1.2. LED DISPLAY

During normal operation of battery, three LED indicators on the front cover provide information about the SOC of the battery with white lights on and off or flashing (0.5S on, 1.5S off) .

☀ : White LEDs are flashing

☀ : White LEDs are glowing

○ : White LEDs are off

LED Indicator	No.	SOC	Description
LEDs show the SOC status	1	☀ ○ ○	$SOC \leq 10\%$
	2	☀ ☀ ○	$10\% < SOC \leq 30\%$
	3	☀ ☀ ☀ ○	$30\% < SOC \leq 50\%$
	4	☀ ☀ ☀ ○	$50\% < SOC \leq 60\%$
	5	☀ ☀ ☀ ☀ ○	$60\% < SOC \leq 90\%$
	6	☀ ☀ ☀ ☀ ☀	$90\% < SOC \leq 100\%$

State Display

The LEDs indicate the operating state of the product.

Standby: all white LEDs are flashing (0.5s on and 0.5s off).

Normal: white LEDs are glowing or flashing (0.5s on and 1.5s off).

Protection: yellow LEDs are glowing or flashing (0.5s on and 0.5s off).

Error: yellow LEDs are glowing or flashing (0.5s on and 0.5s off).

Shutdown: all LEDs are off.

























Protection Display

The three LED indicators on the battery cover provide information about the protection status of the battery .



 : Yellow LEDs are flashing

 : Yellow LEDs are glowing

 : Yellow LEDs are off

LED Indicator	LED Display	Description	Troubleshooting
Yellow LEDs are on or yellow LEDs are flashing once per second.	  	Temperature difference	Wait for automatic recovery. If the problem cannot be solved, please call service.
	  	High temperature	Stop discharging and charging until this display status is eliminated and wait for the temperature to drop.
	  	Low-temperature discharge	Stop discharging until this display status is eliminated and wait for the temperature to rise.
	  	Overcurrent charge	Wait for automatic recovery. If the problem cannot be solved, please call service.
	  	Overcurrent discharge	
	  	Cell overvoltage	
	  	Cell under voltage	Stop discharging and call service immediately.
	  	Low-temperature charge	Stop charging until this display status is eliminated and wait for the temperature to rise.



NOTE:













During work mode, if the protection status “Cell under voltage”    appears, please do the following action:

first, switch off the breaker which is located on the left side of the battery, switch on the breaker and wait for 3~5s, switch off the breaker, then switch on the breaker and wait for 3~5s, switch off the breaker, and finally switch on the breaker of the battery, the BMS will be forced to turn on the MOSFET of discharge so that the energy storage inverter can detect the battery open voltage and charge the battery.

Error State

The three LED indicators on the battery cover provide information about the error status of the battery.

-  : Yellow LEDs are flashing
-  : Yellow LEDs are glowing
-  : Yellow LEDs are off

LED Indicator	LED Display	Description	Troubleshooting
Yellow LEDs are on or yellow LEDs are flashing once per second.		Hardware error	Wait for automatic recovery. If this error persists, please call service.
		Hardware error	
		Circuit breaker open	Switch on circuit breaker after powering off the battery.
		LMU disconnect (follower)	Reconnect the BMS communication cable.
		SN missing	Please call service.
		LMU disconnect (host)	Reconnect the BMS communication cable.
		Software version inconsistent	Please call service.
		Multi-Host	Restart all batteries.
		MOS overtemperature	Power off the battery and power on the battery after 30 minutes.
		Insulation fault	Restart battery. If the problem cannot be solved, call service.
		Total voltage fault	Restart battery. If the problem cannot be solved, call service.
		Precharge failure	Restart battery. In case this error persists, please call service.

6.2. DIMENSIONS

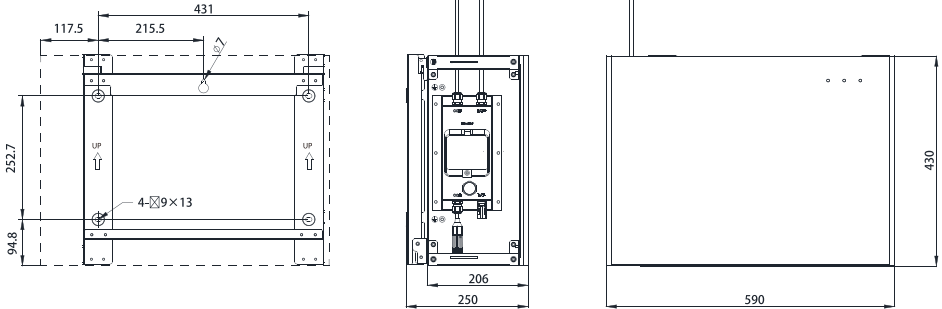

Note: The unit of dimensions is mm.





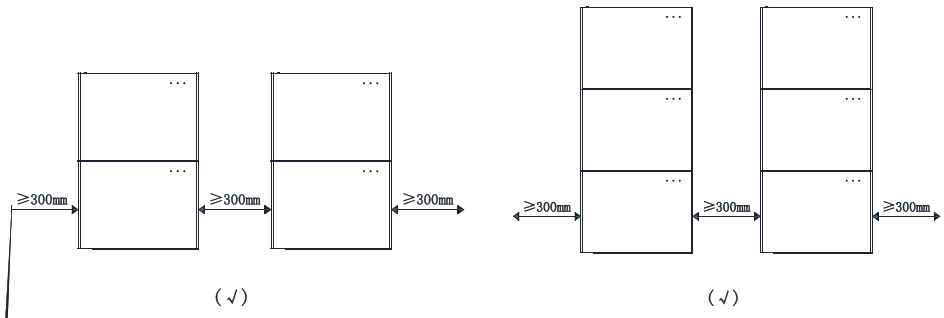





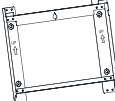

6.3. SPACES

- Reserve sufficient space around the energy storage system to ensure sufficient space for installation, maintenance and heat dissipation.
- The side clearance is a recommendation which can be adjusted according to the end-users requirements. Clearances may be up to 100mm less than noted if ventilation is adequate and no restrictions or objects will limit access to the labelling or switches of the Product or to the use of tools to remove covers or service/remove the Product.









6.4. SCOPE OF DELIVERY

ES-BAT-4.8S

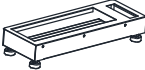
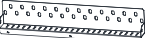
					
Battery (X1)	Left cable cover (X1)	Wall bracket (X1)	Connecting plate for wall brackets (X2)	Right holder for wall bracket (X1)	Left holder for wall bracket (X1)
					
Wall anchor ST6*55 (X6)	Grounding cable (X1)	Small gasket screw M5*12* (X5)	Large gasket screw M5*12 (X3)	Flange nut M5 (X6)	Quick installation guide (X1)

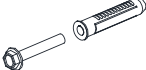
* Use for mounting right holder for wall bracket and left holder for wall bracket

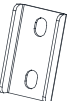
Accessories for Base unit (optional)

			
Base Unit (X1)	Bracket for base (X1)	Bracket for top battery (X1)	Wall anchor ST6*55 (X4)
			
Small gasket screw M5*12(a) (X11)	Large gasket screw M5*12 (X17)	Connection sheet for wall holders (X4)	Wrench SW16 (X1)

(a): Use for mounting wall bracket for base and top battery.

(b): Use for batteries positioning when stacking.

6.5. MOUNTING LOCATION REQUIREMENTS

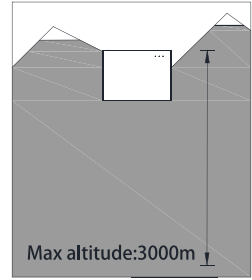
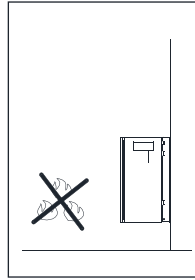
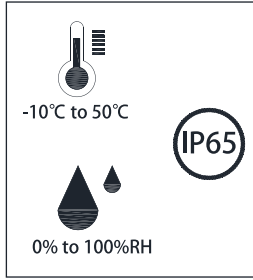
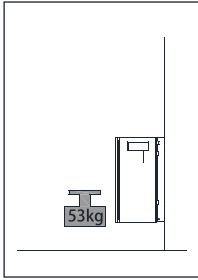

6.6. INSTALLATION

6.6.1. WALL BRACKET INSTALLATION

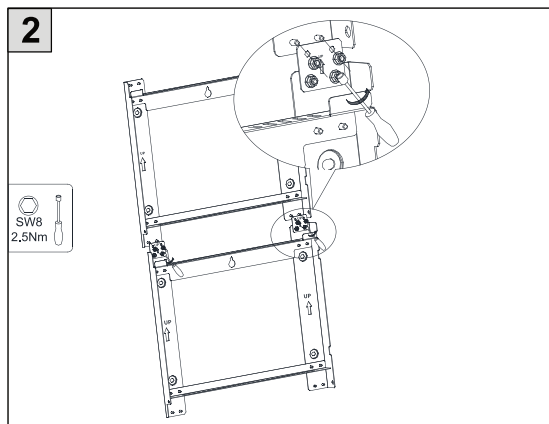
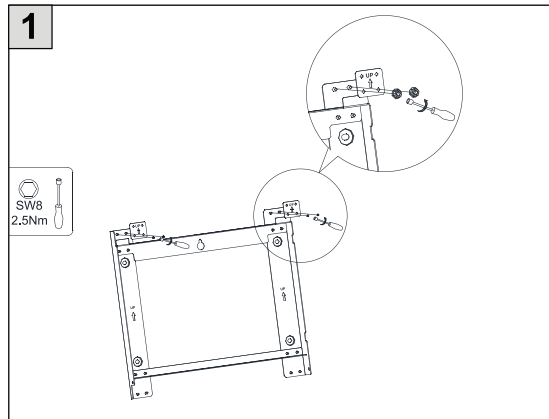

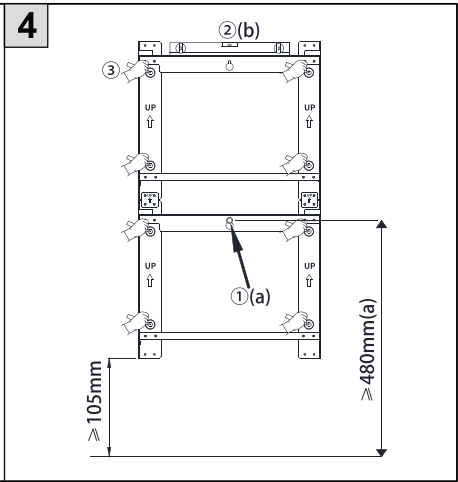
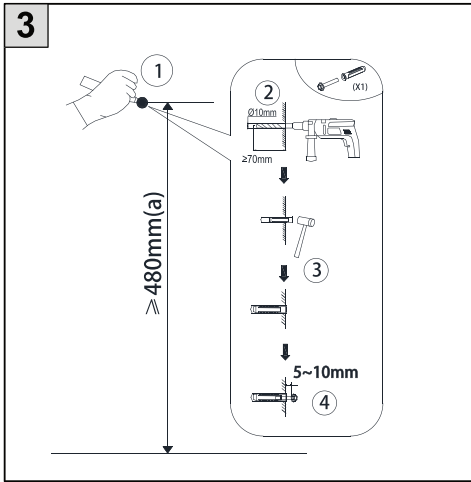

(a) This recommended value is for the location which is the middle hole of the wall bracket for the bottom battery

NOTICE:

(b) Ensure that the wall bracket is mounted horizontally using a spirit level before securing the wall bracket.

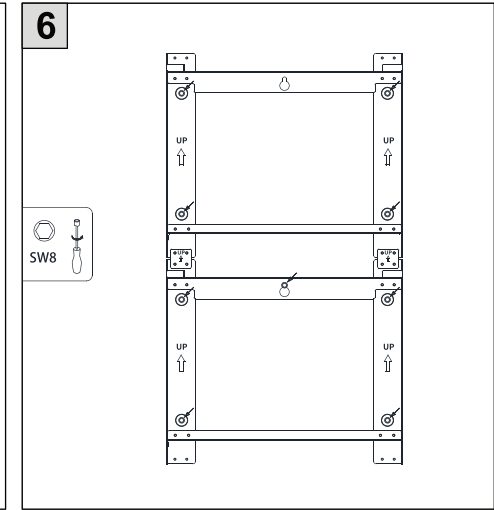
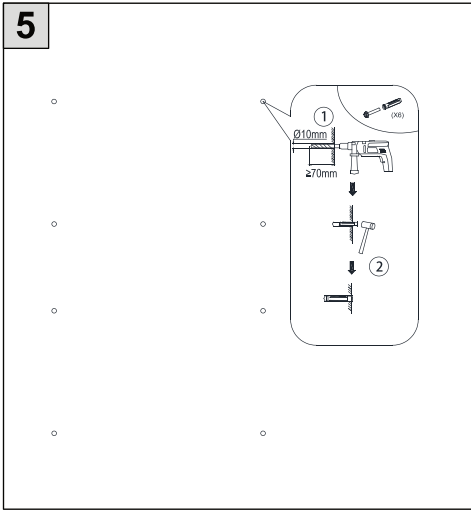

7

T20
2.5Nm

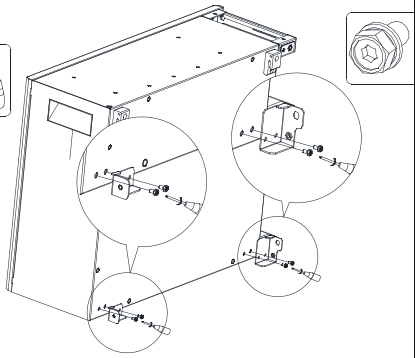

Note: Don't install the bracket upside down.

8

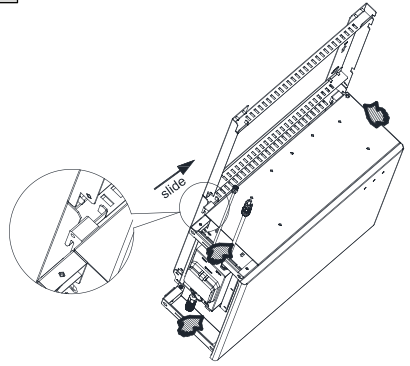

9

T20
2.5Nm

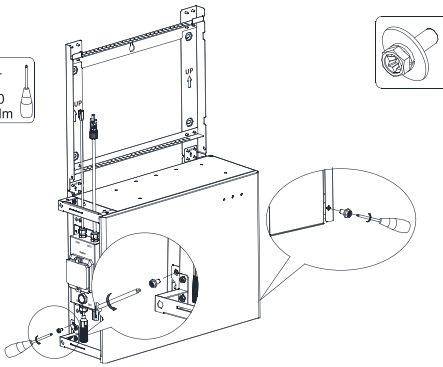

10

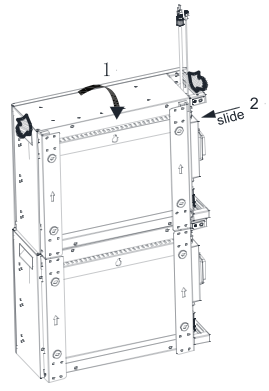

11

T20
2.5Nm

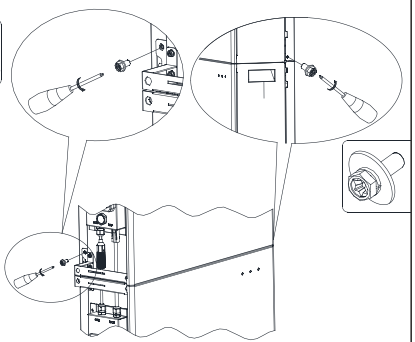

Wall-Mounted Battery Disassembling

CAUTION

Risk of injury due to the weight of the battery

Incorrectly lifting or dropping the battery during transportation, mounting, or disassembling may lead to injuries.

- Transport and lift the battery carefully. Take the weight of the product into account.
- Always have two or more people to mount and disassemble the product.
- Wear suitable personal protective equipment for all work on the product.

When disassembling the battery which has been mounted with wall bracket and not directly connected to the inverter, always hold the handles on both sides of the battery firmly and slide it to the left. Once the contour of the round hole of the upper left handle is close with the left edge of the front cover, carefully lift the battery forward and off the wall bracket.

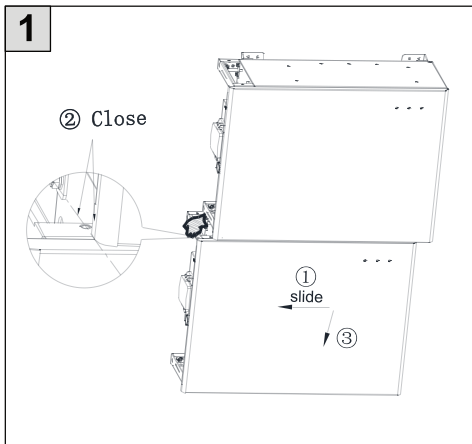

6.6.2. BASE INSTALLATION (OPTIONAL)

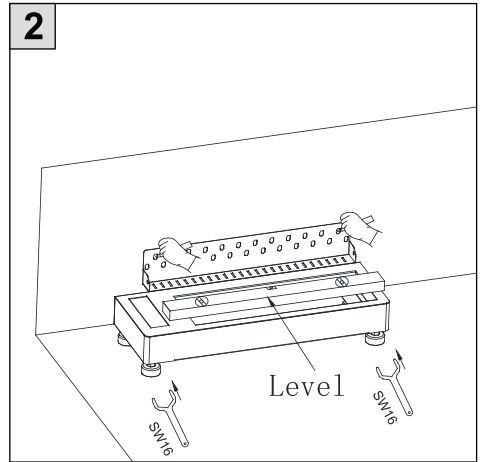
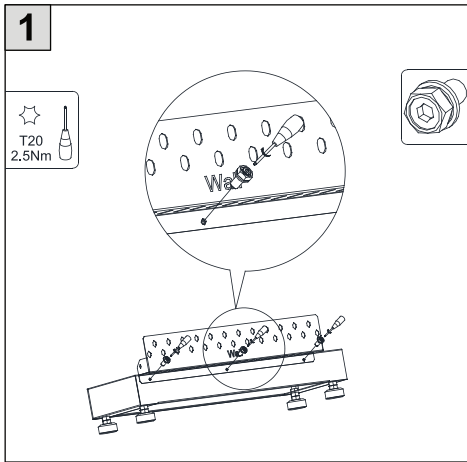

Ensure that the base is mounted horizontally using a spirit level before securing the base fixing bracket.

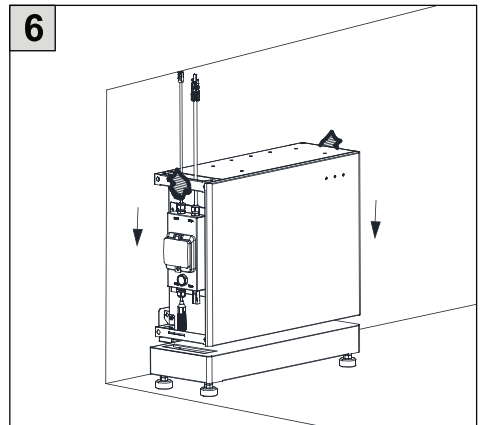
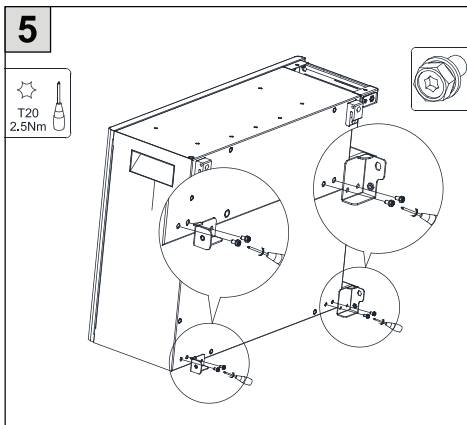
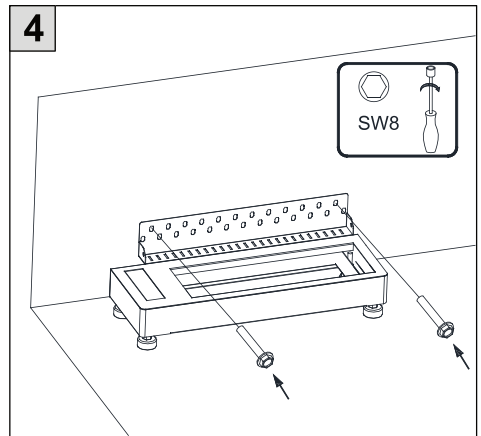
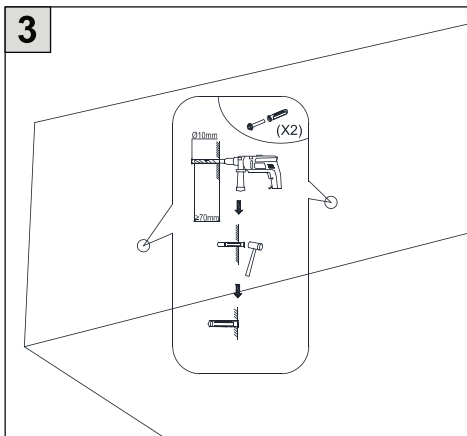

7

T20
2.5Nm

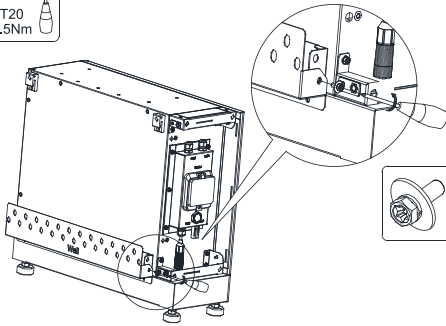

8

T20
2.5Nm

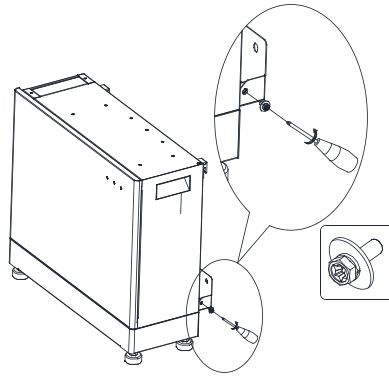

9

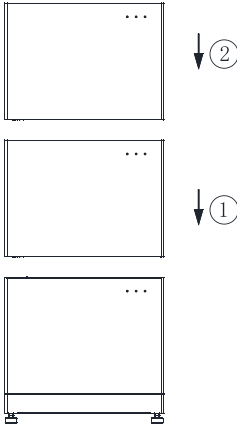

10

T20
2.5Nm

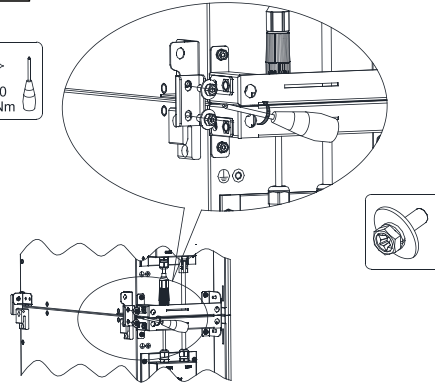

11

T20
2.5Nm

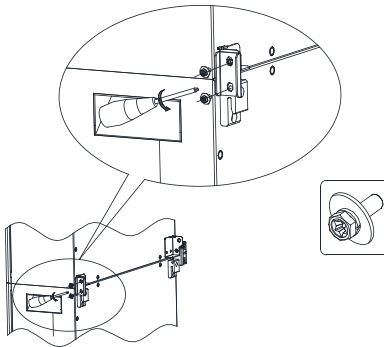

12

T20
1.5Nm

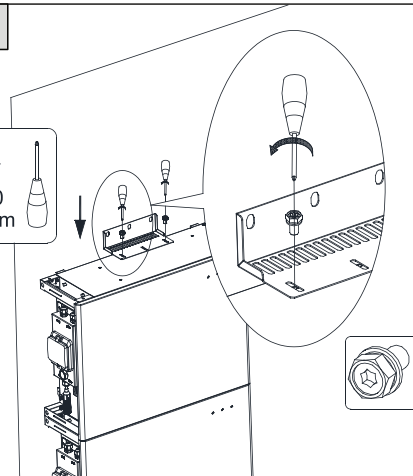

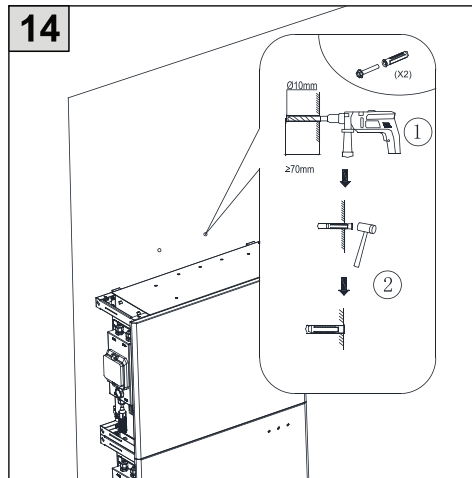
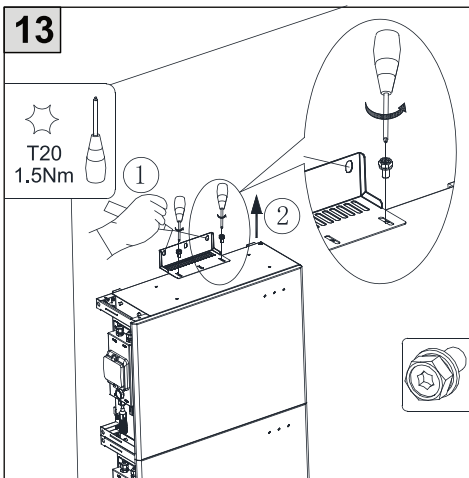

Note: Be careful to prevent dust before drilling the wall

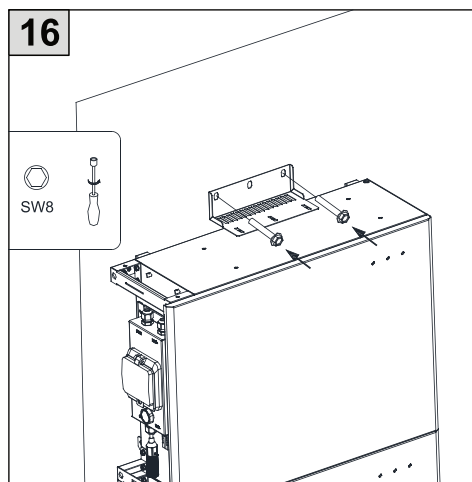
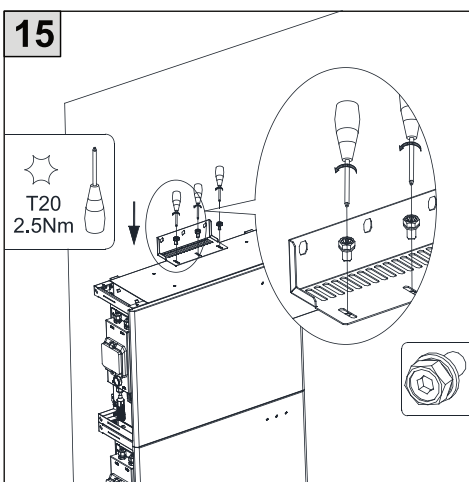

6.7. ELECTRICAL CONNECTION

6.7.1. ELECTRICAL CONNECTION OF THE GROUNDING

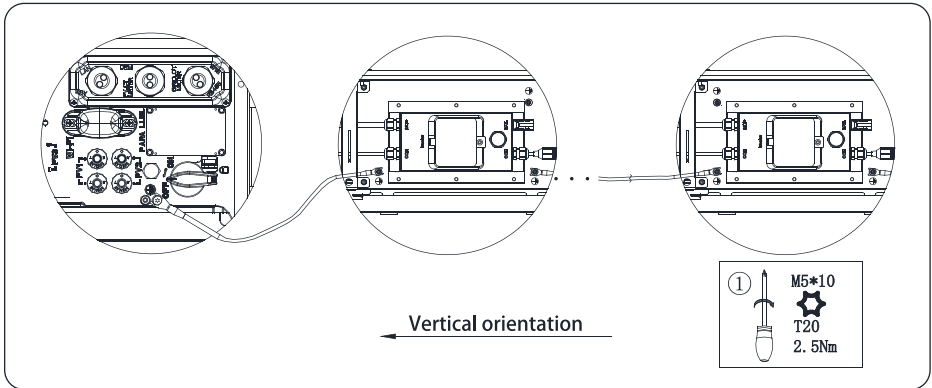

Grounding connection between series batteries and inverter

6.7.2. ELECTRICAL CONNECTION BETWEEN INVERTER AND BATTERIES

⚠ DANGER

Danger to life due to short-circuiting of the battery

Touching the short-circuit connection of the battery can result in significant injuries or even death due to electric shock and massive energy release.

- Switch off the battery breaker located on the lower left of the battery.
- Connect the upper connector of the lower battery to the lower connector of the upper battery. Otherwise, the battery may short-circuit.

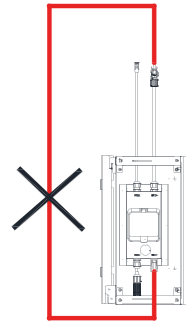

6.7.2.1. ELECTRICAL CONNECTION BETWEEN ES-INV-SPH SERIES INVERTERS AND ES-BAT-4.8S

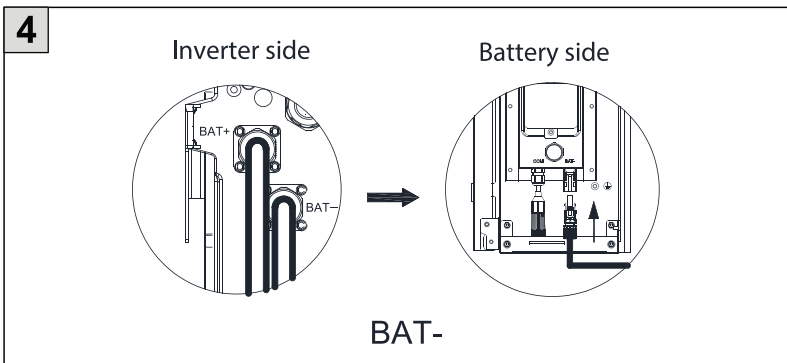
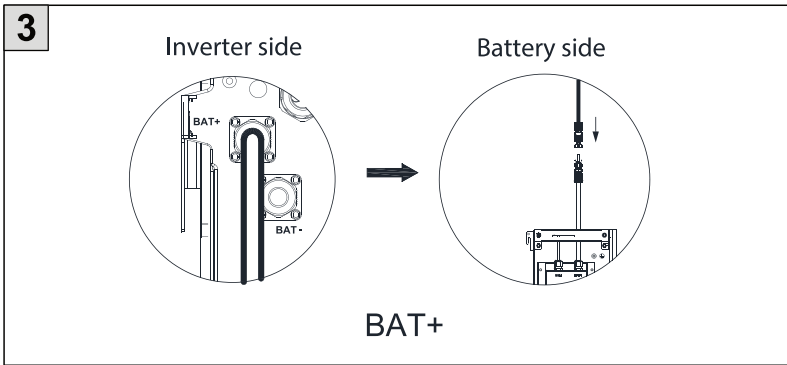
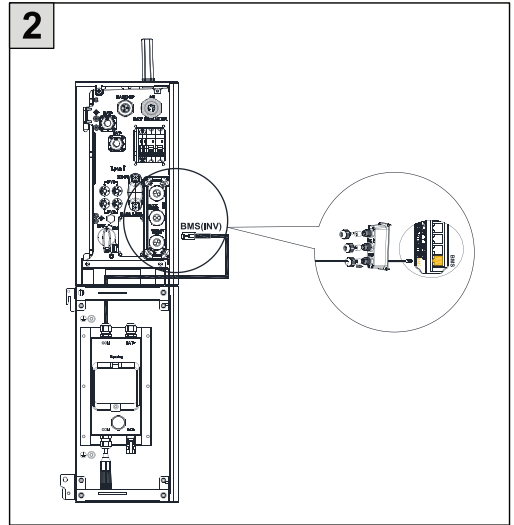
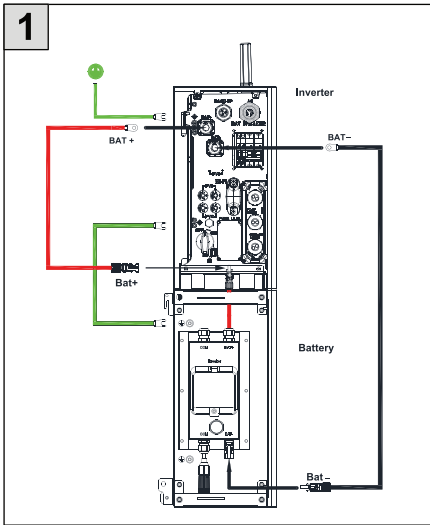

6.7.2.2. ELECTRICAL CONNECTION BETWEEN ES-INV-TPH SERIES INVERTERS AND ES-BAT-4.8S

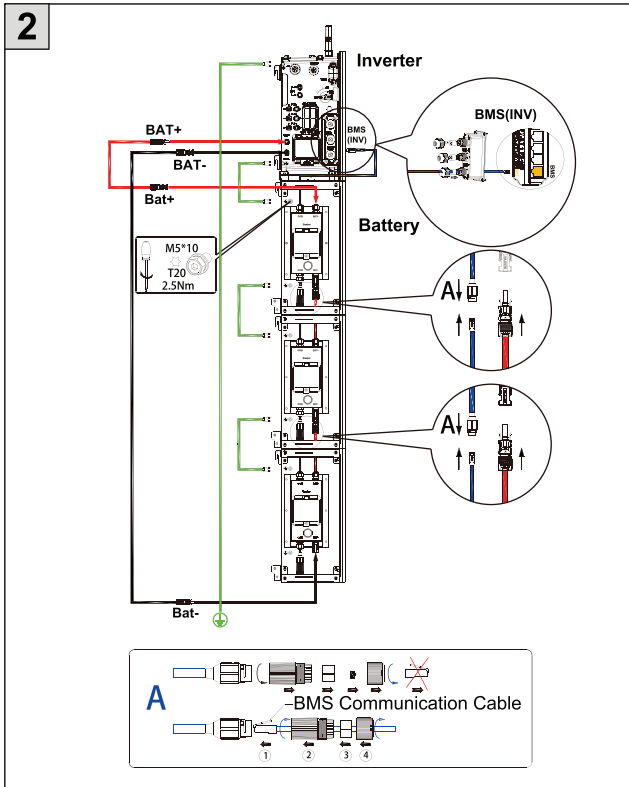
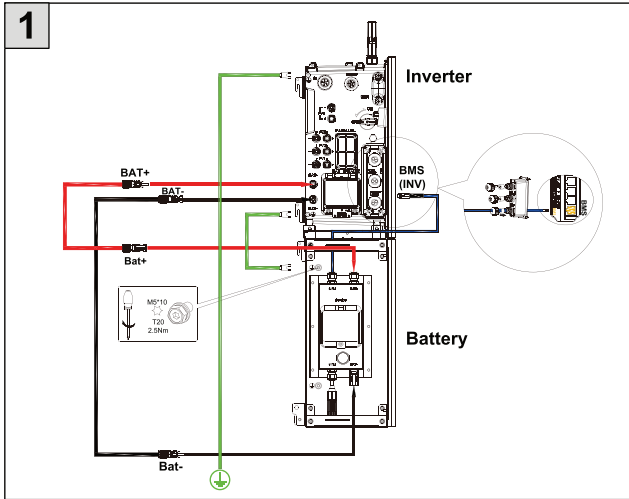

3

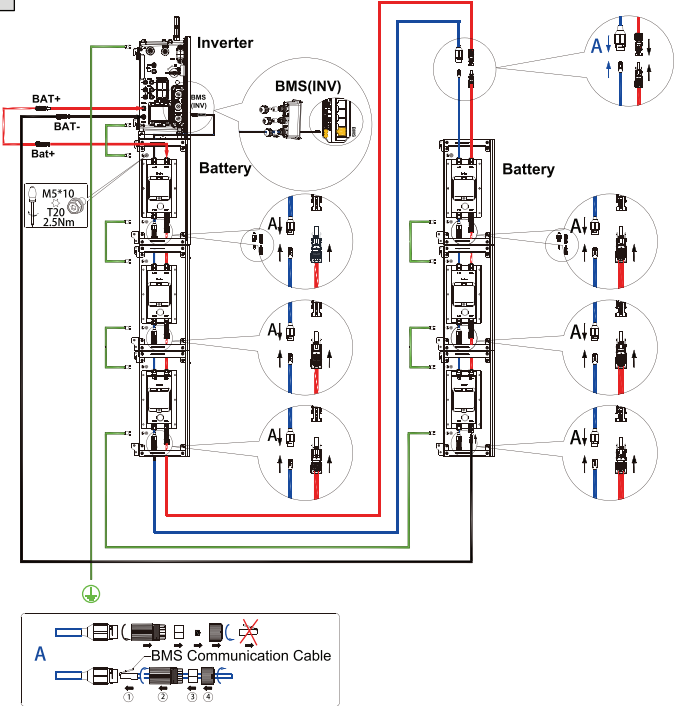

6.8. INSTALL THE CABLE COVER (OPTIONAL)

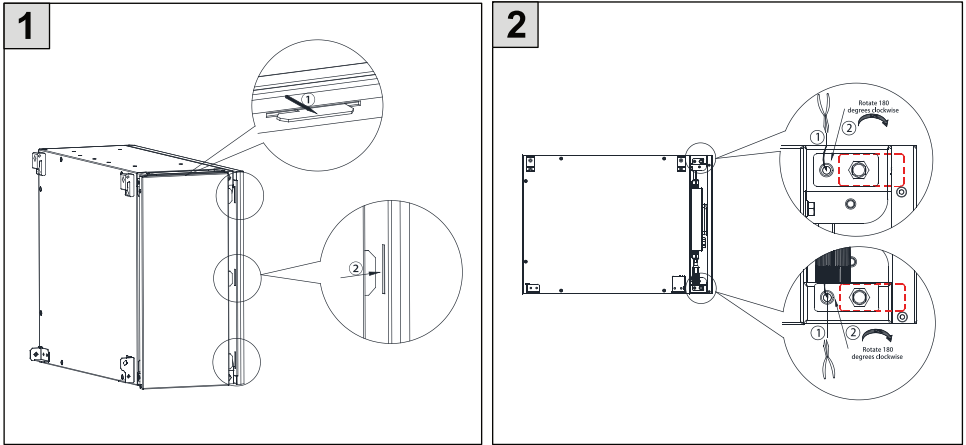

The following steps are only for the top of the second column battery.

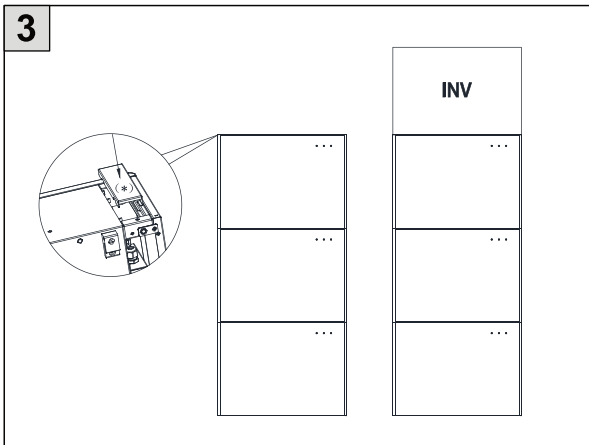

Little cover kit with the (*) is included in the inverter expansion accessory which need to be purchased additionally.

MODEL	ES-BAT-4.8S
Electrical	
Installed Energy	4.8 kWh
Usable Energy	4.56 kWh
Depth of Discharge (DoD)	95%
Nominal Voltage	96 V
Operating Voltage Range	90 - 108 V
Operation	
Max. Charge Current	50 A
Max. Discharge Current	50 A
Operating Temperature Range	Charge: 0<T<50°C / Discharge: -10<T<50°C
Relative Humidity	0 - 100%
Physical	
Battery Type	LFP (LiFePO ₄)
Weight	53 kg
Dimension (W*D*H)	590 x 430 x 206 mm
Ingress	IP65
Battery Expansion	
Modules	1 - 6 in series
Installed Energy	4.8 / 9.6 / 14.4 / 19.2 / 24 / 28.8 kWh
Usable Energy	4.5 / 9.1 / 13.6 / 18.2 / 22.8 / 27.3 kWh
Communication	CAN
Certification	
Transportation	UN38.3
Safety	IEC 62619, IEC 62040

Note: Specification are subject to change without advance notice.





AMPS MIDDLE EAST FZ LLC
#703, 7th Floor, Deira Twin Tower,
Baniyas Square, Deira, Dubai (UAE)

EASTMAN AUTO & POWER LTD.
ASF Towers, 249, Udyog Vihar Phase-4,
Gurugram, Haryana-122016, India

GUANGDONG EASTMAN NEW ENERGY CO., LTD
#1602, Meilan business centre, Intersection of Xixiang Avenue
and Qianjin Second Road, Bao'an, District, Shenzhen-518102, China